

TENDER NO. AAAL/2022-23/MMD/DEL/SLOTTED ANGLE RACKS/472 DTD 03 OCT 2022

TENDER FOR SUPPLY AND INSTALLATION OF
SLOTTED ANGLE RACKS
ALLIANCE AIR IS A WHOLLY OWNED SUBSIDIARY OF AI AHL

Last date & time for submission of Bids: 11.10.2022 at 15:00 Hrs.

Last date & time for opening of Technical Bid: 11.10.2022 at 15:30 Hrs.

TENDER NO. AAAL/2022-23/MMD/DEL/SLOTTED ANGLE RACKS/472 DTD 03 OCT 2022

CERTIFICATE

THIS IS TO CERTIFY THAT THE SUBJECT TENDER DOCUMENT BEARING TENDER NO. AAAL/2022-23/MMD/DEL/SLOTTED ANGLE RACKS/472 DTD 03 OCT 2022 CONTAINS A TOTAL OF 21 PAGES (SERIALLY NUMBERED) TWENTY ONE PAGES ONLY).

TABLE OF CONTENTS

<u>Contents</u>	<u>Page Nos.</u>
	From - To
Chapter -1 : Disclaimer to Bidders	: 4 – 5
Chapter -2 : Instruction to Bidders	: 6 – 11
Chapter-3 : Terms & Condition of Contract	: 12 – 16
Chapter-4 : Work Scope of Tender	: 17 – 17
Chapter-5 : Technical bid format	: 18 – 19
Chapter-6 : Financial bid format	: 20 – 20
Chapter-7 : Annexure – A	: 21 – 21
(Bid Security Declaration Form)	

CHAPTER - 1

DISCLAIMER

1. The information contained in this tender document (hereinafter referred to as the “Tender”) or and any information pertaining to the aforesaid subject matter provided subsequently to the applicants/bidders in any form by ALLIANCE AIR AVIATION LIMITED (hereinafter referred to as “AAAL”) shall be subject to the terms and conditions to which such information is provided contained herein and any other terms and conditions as may be prescribed by AAAL prior to award of the tender.
2. The purpose of this tender is to provide all bidders with the information that may be useful to them in the formulation of their proposals/bids (hereinafter referred to as “BID(S)”) in response to this tender. The statements and facts contained herein, which reflect various assumptions and assessments arrived at by AAAL do not purport to contain exhaustive/all the information on the aforesaid subject matter that each applicant may require for the purpose of submitting their bids.
3. Each bidder should, conduct its own due diligence, investigations and analysis and should check the accuracy, adequacy, correctness, reliability and completeness of the assumptions, assessments, and information contained in this tender and shall obtain independent advice from appropriate sources at no cost to AAAL.
4. The information provided in this tender to the applicants is on a wide range of matters, some of which depends upon interpretation of law. The information given is not an exhaustive account of statutory requirements and should not be regarded as a complete or authoritative statement of law. AAAL accepts no responsibility for the accuracy or otherwise for any interpretation or opinion on the law expressed herein.
5. AAAL also accepts no liability of any nature whether resulting from negligence or otherwise, however caused arising from reliance by any applicant/bidder upon the statements contained in this tender.
6. AAAL may in its absolute discretion, but without being under any obligation to do so, update, amend or supplement the information, assessment or assumption contained in this tender, from time to time till close date of tender.
7. The tender does not imply that AAAL is bound to select a bidder or to appoint the selected bidder, as the case may be, and AAAL reserves the right to reject all or any of the bids without assigning any reason whatsoever at any time.

TENDER NO. AAAL/2022-23/MMD/DEL/SLOTTED ANGLE RACKS/472 DTD 03 OCT 2022

8. The bidder shall bear all its costs associated with or relating to the preparation & submission of its bids including but not limited to preparation, copying, postage, delivery fees, expenses associated with any demonstrations or presentations which may be required by AAAL or any other costs incurred in connection with or relating to in bids. All such costs and expenses shall remain with the bidder and AAAL shall not be liable in any manner whatsoever for the same or any other costs or other expenses incurred by the bidder in preparation for submission of the bid, regardless of the conduct or outcome of the bid selection process as contained herein.

CHAPTER -2

INSTRUCTION TO BIDDERS

1. Alliance Air Aviation Limited (AAAL)-Alliance Air is a wholly owned subsidiary of AI AHL, fully owned by the Government of India under administrative control of Ministry of Civil Aviation and currently operates a fleet of ATR 42-600 and ATR 72-600 aircraft with the brand “**ALLIANCE AIR**” and operates domestic flights within India.
2. AAAL is pleased to invite Bids under the TWO BID format for SUPPLY & INSTALLATION OF SLOTTED ANGLE RACKS. The bids are to be submitted at Alliance Air office at **Alliance Bhawan, Materials department**.
3. Slotted Angle Racks supplying & installation entities involved in supply & installation of Slotted Angle Racks are invited to submit the best offer, as per terms & conditions and work scope of contract as sought in subject tender document (Refer Chap – 3 & 4). The Business entities involved in supply & installation of slotted angle racks having prior experience is only permitted to apply/respond with quotes against subject tender. Entities not having experience in supply & installation of slotted angle racks are strictly not allowed to participate in the subject tendering process, if it is found so, such bids will outrightly be rejected.
4. Slotted Angle Racks supplying and installation suppliers are required to submit quotes in response to subject tender document as per two bid format as mentioned in chapter 4(Tech Bid Format) & 5 (Financial Bid Format) to subject tender document.
5. The Tech bid documents and Financial bid documents are to be enclosed in two separate envelopes. The envelope containing Tech bid is to be superscribed with Tender No. **TECH BID AAAL/2022-23/MMD/SLOTTED ANGLE RACKS/472 Dated 03.10.2022** and Envelope containing **Financial Bid** to be superscribed with Tender No. **FINANCIAL BID - AAAL/2022-23/MMD/DEL/SLOTTED ANGLE RACKS/472 Dated 03.10.2022** and the two separate envelopes pertaining to Tech Bid and Financial bid to be further enclosed in a bigger envelope and is to be super scribed Tender No. **AAAL/2022-23/MMD/DEL/SLOTTED ANGLE RACKS/472 Dated 03.10.2022** and the same to be deposited in tender box kept at the address appended below. Either in person or through Post/courier services.The envelope carrying quotes should either be sealed/closed/Glued. Opened/stapled envelopes will not be accepted.Opened/stapled envelopes will be outrightly rejected.

TENDER NO. AAAL/2022-23/MMD/DEL/SLOTTED ANGLE RACKS/472 DTD 03 OCT 2022

Materials Management Department (MMD)
Alliance Air Aviation Limited,
Alliance Bhawan
IGI Airport, Terminal- 1
Palam, New Delhi -110037

6. Tender documents sent through Post or Courier will be at the risk of the tenderer and AAAL will not be responsible for any loss or non-receipt of the tender documents. Tenders received after due date/time will not be entertained/considered. If tender closing/opening date is declared a Holiday in AAAL, Delhi Office, the last date of submission/opening of the Bids will automatically stand extended to 15:00 Hrs of the next working day.

7. Last date & time for submission of Tender: 11.10.2022 at 15:00 PM.

8. There is no Tender Fees as the tender can be downloaded free of cost, from AAAL's website- www.allianceair.in

9. Due date & time for opening of Tech Bids submitted: 11.10.2022 at 15:30 PM (date of opening of financial bids of those bidders who emerge as successful in technical evaluation upon opening of technical bids will be notified latter).

10. Amendments, corrigendum, clarifications if any and any extensions of due date & time of opening of this tender will be duly intimated.

11. For any queries / clarifications w.r.t technicalities/Scope of work w.r.t the subject tender **Mr. Vijay Kumar (Designation- Chief of MMD) MOB No. 7500 312 014** may be contacted on any working day between 10 AM to 16:30 PM before Tech bid opening date and time.

12 It is further clarified that any individual signing the tender or other documents in connection with the tender must certify whether he signs as:

- ◆ A "Sole Proprietor" of the firm or constituted attorney of such sole proprietor
- ◆ A partner of the firm if it is a partnership must have authority to refer to arbitration, disputes concerning the business of the partnership either by virtue of the partnership agreement or a power of attorney. In the alternative, the tender should be signed by all the Partners.
- ◆ Director if it is a One Person Company.
- ◆ Constituted attorney of the firm, if it is a Company.
- ◆ Authorized signatory of the firm.

13. Financial quotes should be filled in prescribed format (as per Chapter – 6 to subject tender document) duly signed and stamped and prices be clearly written/typed both in words and figures without any overwriting. Corrections & overwriting, if any, should be counter signed by the tenderer. If there exists any doubt with respect to the price mentioned the price mentioned in words will be taken as the final quote.

TENDER NO. AAAL/2022-23/MMD/DEL/SLOTTED ANGLE RACKS/472 DTD 03 OCT 2022

14. Tech bids are to be filled as per prescribed format (as per chapter – 5 to tender document), it should be duly signed and stamped and the technicalities clearly mentioned without ambiguity. Utmost care to be taken **not to state the Financial quotes in Tech bid documents**, if it is found that the financial quotes are stated in Tech bids the complete bid from such parties/vendor(s) are liable to be rejected.
15. Tenderers are advised to study the tender document carefully. Submission of tender shall be deemed to have been done after careful study and examination of the tender document with full understanding of its implications.
16. Conditional bids would not be accepted, and are liable to be rejected.
17. In the event of default in performance of services/Supplies or both together, AAAL reserves the right to cancel the contract order entered into, and also will initiate claims against damages from the successful tenderer, and also AAAL reserves the right to award the contract to another vendor at the cost and risk of the successful tenderer.
18. The firm should be mandatorily registered with GSTN and should hold GSTN number for invoicing.
19. The tender is for SUPPLY & INSTALLATION OF SLOTTED ANGLE RACKS from reputed SUPPLIERS/MANUFACTURERS OF REQUISITIONED MATERIAL holding all mandatory industry certification, permissions and licenses. For any queries, Bidders are to contact AAAL, Materials Department in person between 9:30hrs to 16:30Hrs or through telecommunication on above mentioned Mobile No. Tenderers not dealing/having NIL experience in SUPPLY & INSTALLATION OF SLOTTED ANGLE RACKS business need not apply / respond to subject tender as their quotes will be rejected outright.
20. The Supplies to be rendered is to be as per requirements mentioned in Chapter – 4 to subject tender document.
21. The cancellation of tender solely vest with AAAL, and tender can be scrapped before offering of Service order/LOI/Contractual Agreement to L1 vendor or at any time as deemed to be fit by AAAL before service order/contractual agreement is handed over to vendor without any prior notice and the same will be notified at a later stage after decision is implemented.
22. The bid opening date will be extended to new date if required number of minimum participants doesn't responds to the published bid or as deemed to be fit by the tender convening authority or AAAL Competent authority, as per material rules & regulations of AAAL. The extended date of bid opening will be notified to the bid participants.

TENDER NO. AAAL/2022-23/MMD/DEL/SLOTTED ANGLE RACKS/472 DTD 03 OCT 2022

23. L1 Vendor is to transfer price advantage on service/Supplies being provided/rendered to AAAL arising due to any reduction in applicable taxes for services being rendered/supplies being effected.

24. All pages of the tender document to be signed by vendor, signing the financial quotes and thus signed tender document along with financial quotes to be submitted while submitting the Bids as per format mentioned in Chapter – 6 in the tender document.

25. The Scope of supplies/services that are to be delivered/rendered should be as per the details mentioned in the tender document that is being circulated and against which the bids are to be furnished.

26. On tender opening date vendors/representatives of vendors who have submitted bids against subject tender are welcome to witness the event. **The participant should hold valid authorisation letter/valid Identity card issued by the company. The participant/representative not in possession of authorisation letter/valid identity card will not be allowed to attend the tender opening process.**

27 If a firm quotes NIL charge/consideration in the bid submitted against subject tender enquiry, the bid shall be treated as unresponsive and will not be considered for further evaluation.

28. All quotations to be submitted only in INR.

29. Conditional discounts, if any shall not be given any consideration for L1 Purpose

30. Tenders should be duly signed and stamped on every page by an authorised signatory of the tenderer.

31. The price quoted should be clearly typed /written in figures and words, free from corrections or overwriting. Corrections, if any, must be authenticated by the full signature of the person who has signed the quotation. If there exists any variation in figures and words, **amount mentioned in words will be considered as final.**

32. GROUNDS FOR REJECTION OF BIDS

The bids are liable to be rejected forthwith i.e, without being evaluated, on the following grounds:

32.1 If the tender has been received after the closing date/time of the tender.

32.2 if only the technical bid has been received and the commercial bid has not been received, and vice versa.

32.3 If the tender has been received by email, open condition, or fax instead of in separate sealed/closed covers.

TENDER NO. AAAL/2022-23/MMD/DEL/SLOTTED ANGLE RACKS/472 DTD 03 OCT 2022

- 32.4 If the tender has not been signed by the authorized signatory of the tenderer
- 32.5 If the technical bid has been received without bid security or Bid Security declaration as applicable (Refer Chap – 5 as per tender document).
- 32.6 In case the price bid and the tech bid are enclosed in the same envelope instead of two different envelope in separately sealed/closed state, the tender will be liable to be rejected.
- 32.7 In case if it is found that tech bid contains indications of price bid, then in such case subject bids will be rejected.
33. Price bids of only those tenderers, who are found suitable based on evaluation of their technical bids, would be opened for further evaluation, and accordingly such tenderers would be intimated in advance of the date of opening of the price bids by E-MAIL and, or by telephone.
34. **INSURANCE** – All consignments required to be handled by the successful tenderer must be covered by insurance against loss, theft, arson, accidental loss etc (comprehensive coverage) and the cost component mentioned in tender document should include the insurance cost also.
35. **FORCE MAJUERE CLAUSE:**
- (a) Neither party shall bear responsibility for the complete or partial non-performance of any of its obligations (except for failure to pay any sum which has become due on account of receipt of goods/services under the provisions of the present contract), if the non-performance results from such Force Majeure circumstances as Flood, Fire, Earth Quake and other acts of God as well as War, Military operation, blockade, Acts or Actions of State Authorities or any other circumstances beyond the parties control that have arisen after the conclusion of the present contract.
- b. In such circumstances the time stipulated for the performance of an obligation under the present contract is extended correspondingly for the period of time of action of these circumstances and their consequences.
- c. The party for which it becomes impossible to meet obligations under this contract due to Force Majeure conditions, is to notify in written form the other party of the beginning and cessation of the above circumstances immediately, but in any case not later than 10 (Ten) days from the moment of their beginning.
- d. Certificate of a Chamber of Commerce (Commerce and Industry) or other competent authority or organization of the respective country shall be a sufficient proof of commencement and cessation of the above circumstances.
- e. If the impossibility of complete or partial performance of an obligation lasts for more than 2 (two) months, either party hereto reserves the right to terminate the contract totally or partially upon giving prior written notice of 30 (thirty) days to the

TENDER NO. AAAL/2022-23/MMD/DEL/SLOTTED ANGLE RACKS/472 DTD 03 OCT 2022

other party of the intention to terminate without any liability other than reimbursement on the terms provided in the agreement for the goods/services received.

CHAPTER -3

TERMS AND CONDITIONS OF CONTRACT

1. **CONTRACT BEGINNING:** The contract start date will be from the date of furnishing Purchase Order to L1 Vendor.
2. **CONTRACT CLOSURE:** The contract End date will be 60th day POST SUCCESSFUL COMPLETION OF SUPPLY OF TENDERED MATERIAL and services mention in tender document(Supply and Installation of Slotted Angle Rack) as per quantity mentioned in subject tender. If supplies/services are not effected as per schedule of requirement, **Liquidated damages will be charged at the rate 0.5% of the value of the contract per week or part thereof for the undelivered goods / services or as deemed to be fit by AAAL authorities.** Exception to this clause is when clause no 34 to Chapter 2 is effective/executed.
3. **BID OFFER VALIDITY CLAUSE:** The Bid offer price should be valid for 90 days from the date of opening the financial bids. Further to it the price quoted in financial bid without GST should remain the same till the supply of complete quantity/delivery of contractually agreed supplies/services in totality as per contract agreement between AAAL and L1 party/negotiated L1 party till it is delivered/rendered at premises as stated by AAAL in contract agreement. No enhancement of rates will be allowed and the supplies/services are to be effected on L1 rates throughout the contracted period or during extension period of contract. Payment from AAAL will only be made against L1 rates plus applicable taxes.
4. **EMD / BID SECURITY:** An amount of **Rs. 15,000/- (Rs. Fifteen Thousand only)** to be deposited as an EMD / BID SECURITY **by an Account Payee Demand Draft in favour of ALLIANCE AIR AVIATION LIMITED Payable at DELHI.** MSME Units are exempted from submission of EMD. However this exemption is applicable only if the MSME unit is registered for the goods / services tendered for. Also, EMD would not be applicable for Public Sector Units, Govt Undertakings. Bid Security Declaration Form duly filled and signed to be rendered by the bidders who are exempted from depositing EMD / Bid Security amount as mentioned above.
5. **EMD FORFEITURE:** Penal measures as stated in **BID SECURITY DECLARATION FORM** as per **Annexure- A** to subject tender document will be applicable.
6. **SECURITY DEPOSIT:** Successful bidders are required to deposit Security deposit to the tune of 3% of the value of the contract as specified in bid documents. Security Deposit are to be furnished in the form of Demand Draft drawn in favour of ALLIANCE AIR AVIATION LIMITED Payable at NEW DELHI.

TENDER NO. AAAL/2022-23/MMD/DEL/SLOTTED ANGLE RACKS/472 DTD 03 OCT 2022

The security deposit is to be submitted by L1 vendor on placing and accepting of LOI. The Security deposit to be submitted within 7 working days from the date of LOI release.

7. **SECURITY DEPOSIT REFUND:** Security Deposit will be valid/returned after a period of 90 days (Ninety **days**) beyond the completion of all contractual obligation of the supplier. Security deposit thus deposited will be returned back without interest and no claim of interest on the security deposit amount will be entertained.

8. **EMD REFUND:** EMD furnished by the successful bidders would be returned to them free of interest within 45 days of issue of the Purchase Order / conclusion of the contract. EMD of the successful bidder would be refunded without any interest after receipt of Security Deposit from the vendor.

9. **CONTRACT DISHONOUR CLAUSE:** Non supply of materials/services /abandoning of contract will cause forfeiting of security deposit from the deviating supplier/service provider and orders of such deviating suppliers/service providers will be routed to L2 vendor or subsequent participants of subject tender, if thus approached subject participant/vendor shows his readiness to supply goods/deliver required services at the L1 Vendor rates, or otherwise the tender will be scrapped and new tender will be floated for subject material/services.

10. **CAPACITY CHECK OF BIDDERS FOR QUALITY SERVICE DELIVERY:** To execute the capacity check of bidders for quality service delivery, the committee formed for execution of subject tender is free to requisition any documents/ execute premise visit as deemed to be fit by the committee. All participants responding to subject tender has to mandatorily cooperate in subject activity.

11. **NATURE OF SUPPLIES/SERVICES:** The supplies/services by contracted L1 vendor in tendering process are to be effected as per Work scope mentioned in **Chapter – 4** to subject Tender and as per specifications/details of supplies requisitioned as per contract mentioned in Chapter – 4 to subject Tender. Also all clauses as per subject tender document is applicable for execution of subject contract. No deviations are accepted. If there emanates any deviation, credible documentary evidence should be furnished for waiver. The approval of waiver will be the sole discretion of **Competent Authority of AAAL. If no credible evidence is submitted then penalty as deemed to be fit by AAAL authorities to make good the loss caused due to deviation will be imposed/executed.**

12. **NATURE OF QUOTED RATES:** The rates quoted by bidders are to be inclusive of all charges or any other charges that affect the delivery of goods/materials requisitioned/services rendered. No hidden charges will be

TENDER NO. AAAL/2022-23/MMD/DEL/SLOTTED ANGLE RACKS/472 DTD 03 OCT 2022

entertained post finalisation/during finalisation of contract at any cost, resulting in increase of L1 RATES. **The quoted rate shall be valid for 90 days mandatorily if any deviation then it is the prerogative of AAAL authorities to cancel such bid during technical evaluation.**

13. **DELIVERY ADDRESS:** The requisitioned supplies as mentioned in tender and contracted as per agreement post finalisation of financial bids, by L1 Vendor has to be delivered at the following address.

**LM Block
Terminal- 2
I.G.I. Airport,
New Delhi - 110037**

14. **INVOICING ADDRESS:** The address for invoice generation by L1 Vendor is hereby appended below.

**Material Management Department
Alliance Air Aviation Limited
Alliance Bhawan
Domestic Terminal- 1
I.G.I. Airport,
New Delhi – 110037**

❖ **AAAL GSTN No is : 07AAACA1517B1ZI**

15. **PAYMENT TERMS:** Payment against delivery of goods / services/ completion of work will be effected within **45 days from the date of submission of invoice(s)**, provided the supplies/services are as per specification/contractual agreement and quality mentioned in tender document/contractual agreement.

17. **ERROR/DEFECT DEFINITION CLAUSE:** The definition of erroneous supplies /defective material/Poor delivery of supplies/services is if the material that is being supplied/delivered by Successful/negotiated/contracted vendor is deviating from the specifications/stipulations or clauses mentioned in the tender document or allied services is deficient and compromising in quality. Violation of Govt Of India Rules and regulations while execution of contractual agreement by L1 Vendor will also be considered as ERROR/DEFECT/SUBSTANDARD delivery of supplies from the contracted party. Upon encountering such cases immediate Penal procedures as deemed to be fit by AAAL Authorities will be executed without furnishing any notice period provided such defect has occurred within the contractual period/time frame. The penal imposition will be restricted to the value of loss incurred. The value of LOSS incurred will be assessed calculated and implemented by AAAL Finance Department.

TENDER NO. AAAL/2022-23/MMD/DEL/SLOTTED ANGLE RACKS/472 DTD 03 OCT 2022

18. **REJECTION CLAUSE:** The erroneous/defective materials supplied or services rendered, will be rejected and has to be replaced/redone by L1Vendor/negotiated L1 vendor at no extra cost and within 10 working days from the date of reporting of error/rejection in supplies by AAAL, MMD to L1Vendor, if the erroneous supplies/services are not made good within said time limits AAAL holds the right to forfeit equivalent amount of Security deposit from L1 Vendor. Also the Competent Authorities at Alliance Air can unilaterally take decision in halting/scraping of the contract if at any time it is felt that Quality and Quantity of the supplies are compromised. Any of the mentioned actions or combined action along with penal actions can be initiated and imposed as deemed to be fit by AAAL Authorities.

19. **OPTION CLAUSE:** To take care of change in the requirement during contract period, a plus/minus option clause of 25 %(Twenty Five percent) is hereby included in subject tender document, Alliance Air reserves the right to increase or decrease the materials/quantum of services that is being contracted through subject tender up to the mentioned limit of 25 %(Twenty Five percent) without any change in terms and conditions and rate quoted by the bidders.

20. **Resolution of Disputes and Arbitration Clause:**

20.1 Any dispute arising between the service provider and AAAL (Party/Parties), in respect of the construction, interpretation, application, meaning, scope, operation or effect of the contract or the validity or breach thereof(the "Dispute"), shall first be settled by mutual consultation between the authorized representatives of the parties. If the dispute remains unresolved after a period of 30(Thirty) days from the date when mutual consultation has, the same shall be settled and finally resolved by arbitration.

20.2 Any dispute or differences, whatsoever arising between the parties out of or relating to the construction, interpretation, application, meaning, scope, operation or effect of the service contract or validity or the breach thereof, shall be referred to "SCOPE FORUM OF CONCILIATION AND ARBITRATION- GOVT OF INDIA" and the award made in pursuance thereof shall be binding on the parties to the arbitration.

20.3 Each party shall bear their own cost with respect to such arbitration.

20.4 Any Dispute whatsoever arising out of this contract shall be subject to the exclusive jurisdiction of the courts of New Delhi Only.

21. **Legal status:** The relationship of the parties shall be that of independent contractors. Nothing in this contract shall be construed to create a joint venture,

TENDER NO. AAAL/2022-23/MMD/DEL/SLOTTED ANGLE RACKS/472 DTD 03 OCT 2022

agency or partnership or similar relationship between the parties, or to authorize a party to act as an agent or representative for the other party. No Party shall have express or implied authority to bind or represent the other party for any purpose whatsoever unless expressly agreed in writing by the other party.

22. **Severability:** If any clause, section or provision of this contract is found to be invalid, illegal or unenforceable, by the provisions of the applicable law, such invalidity, illegality or unenforceability shall not render the remaining clauses, sections or provisions hereof invalid, illegal or unenforceable. In such a case, the parties shall amend this contract as appropriate, Seeking to achieve the minimum extent necessary to make this contract, legal valid and enforceable.

23. **Price Negotiation:** As a general norm price negotiation is not to be carried out with the bidders. Negotiations, if at all, shall be an exception and may be held for better pricing with the L1 bidder only and with the L2, L3 and so on bidders, only in case of split of the Services/Value.

24. **Benefits to Micro and Small Enterprises (MSEs):**

i) As per Public Procurement Policy for Micro & Small Enterprises (MSEs) Order, 2012 issued vide Gazette Notification No.503 dated 23.03.2012 by Ministry of Micro, Small and Medium Enterprises of Govt. of India, MSEs must be registered with any of the following in order to avail the benefits/preference available vide Public Procurement Policy MSEs Order, 2012.

- (a) District Industries Centers (DIC)
- (b) Khadi and Village Industries Commission (KVIC)
- (c) Khadi and Village Industries Board
- (d) Coir Board
- (e) National Small Industries Corporation (NSIC)
- (f) Directorate of Handicraft and Handloom
- (g) Any other body specified by the Ministry of MSME ii.

ii) The registration certificate issued from any one of the above agencies must be valid as on close date of submission of Bids. The Successful Bidder should ensure that the same is valid till the end of the contract period.

iii. The MSEs, who have applied for registration or renewal of registration with any of the above agencies/bodies but have not obtained the valid certificate as on close date of the Tender, are not eligible for exemption/preference.

***Important Note:-** Bidder expecting to get MSE benefit(s) must submit their valid MSE certificate for the above-said work-scope/category along with the technical bid**.

CHAPTER -4
WORK SCOPE OF TENDER

1. Workplan (Diagram) may be found in Annexure- B annexed herewith.
2. Detailed Description of the Workplan may be found as Annexure- C annexed herewith.

CHAPTER -5
TECHNICAL BID FORMAT

SUBJECT TECH BID FORMAT TO BE SUBMITTED ON VENDORS LETTER HEAD

SI no	Description	AAAL CONDITIONS	VENDOR RESPONSE	DOCUMENT PROOF
1	Tenderer should have its own offices at Delhi. Address proof to be submitted	MUST	YES/NO	To submit document proof
2	Tenderer should have a minimum average annual turnover of Rs 1 Crore or equivalent foreign currency during the immediate previous three financial years. Certificate duly signed by the chartered Accountant to be submitted in support of the same	MUST	YES/NO	To submit document proof
3	Tenderer should have the experience in supply & Installation of SLOTTED ANGLE RACKS. Copies of invoices/trade challan for supplies & Installation of SLOTTED ANGLE RACKS to be furnished ,for immediate last three years as documentary proof.	MUST	YES/NO	To submit document proof
4	Tenderer should conform compliance to the stated work scope at Chapter – 4 to subject tender document in entirety and confirm that the commercial bid submitted is as per commercial bid format furnished in Chapter – 6 to subject tender document.	MUST	YES/NO	To confirm
5	Tenderer falling in the category of MSME or Govt / Public Sector Undertakings should enclose Bid security declaration as a part of the technical bid in the format mentioned in Annexure A to	MUST	YES/NO	To submit document proof

TENDER NO. AAAL/2022-23/MMD/DEL/SLOTTED ANGLE RACKS/472 DTD 03 OCT 2022

	subject tender document. Non MSME / Non Govt/ Non PSUs bidders are to submit EMD / Bid Security in the form of a Demand Draft as a part of Technical bid (Ref. Chapter – 3, Clause No. 4.			
6	Tenderer agrees to pay noninterest bearing security deposit as mentioned in tender document as security deposit, for the period as mentioned in Chapter – 3, Clause No. 6 & 7.	MUST	YES/NO	To confirm
7	Tenderer agrees that the payment against invoice will be made within 45 days on successful completion of delivery of the goods / services provided and submission of the invoice(s).	MUST	YES/NO	To confirm
8	PAN and GST number	MUST	YES/NO	To submit document proof

TENDER NO. AAAL/2022-23/MMD/DEL/SLOTTED ANGLE RACKS/472 DTD 03 OCT 2022

CHAPTER -6
COMMERCIAL BID FORMAT

COMMERCIAL BID TO BE SUBMITTED ON VENDOR'S LETTER HEAD

SL NO	DESCRIPTION	QTY	UNIT RATE (EXCL OF GST)	TOTAL AMOUNT EXCL OF GST
1	SUPPLY AND INSTALLATION OF SLOTTED ANGLE RACKSNOS		
2	GST RATE			

Chapter – 7
ANNEXURE – A

SUPPLY AND INSTALLATION OF SLOTTED ANGLE RACKS

BID SECURITY DECLARATION FORM

(To be submitted on the Bidder's Letterhead)

Date: _____

Tender Reference _____

To

Alliance Air Aviation Limited,

I/We, the undersigned declare that:

I/We understand that according to your conditions, Bids must be supported by this Bid Security Declaration.

I/We, accept that I/We may be disqualified from bidding for any contract with you for a period of one (01) year from the date of such notification/ intimation to us in the event I/ We are found to be in breach of the terms & conditions and obligations of this Tender due to any of the following reasons:

- a) If I/We have withdrawn/ modified/ amended our Bids, or have impaired or derogated from the Tender conditions or our submitted Bids during the Bid validity period; or
- b) If I/ We have been notified about the acceptance of our Bid and have been awarded the letter of intent for execution of the Contract pursuant to the bidding process during the Bid validity period and I/ We either
 - (i) fail to accept the letter intent or execute the Contract and/or
 - (ii) fail to furnish the requisite Security Deposit? Performance security in accordance with the instructions given to the Bidders.

I/ We understand that the Bid Security Declaration shall cease to remain valid in case I/ We are not the Successful Bidder, upon earlier of (i) the receipt of your notification regarding the name of the Successful Bidder; or (ii) thirty days of the expiration of validity of my/ our Bid.

Signed:

[Insert name and capacity of the person authorized to sign]

Duly authorized to sign on behalf of the [insert complete name of the Bidder Date on this (*) day of (*) month, 2021

Corporate seal of the bidder

1.) ROOM R & D

TOTAL HEIGHT - 3030 mm

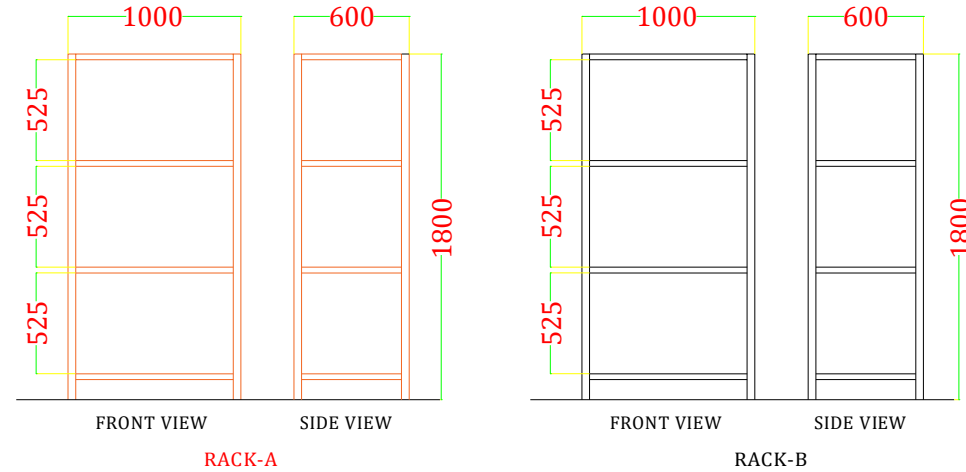
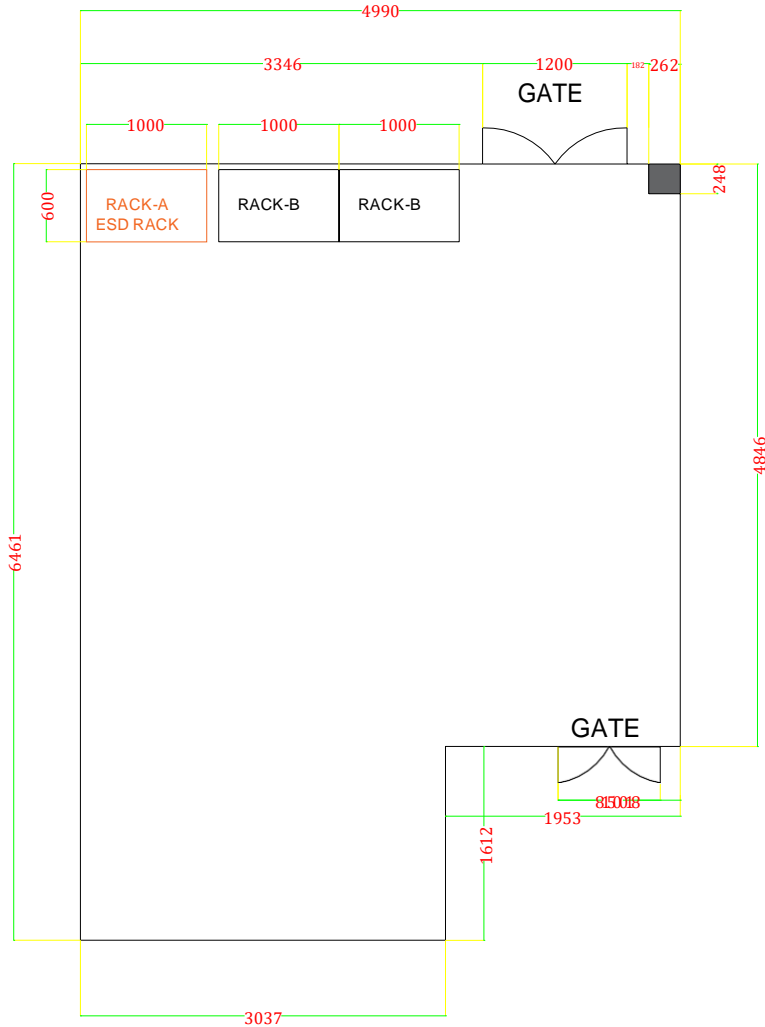

NOTE - ALL NEW RACK WITH NAME PLATE
ESD SLOTTED ANGLE RACKS

DIMENSION	SHELF	COMPARTMENT	H	L	D	Q
RACK-A	04	03	1800	1000	600	01

SLOTTED ANGLE RACKS

DIMENSION	SHELF	COMPARTMENT	H	L	D	Q
RACK-B	04	03	1800	1000	600	02

UNLESS OTHERWISE SPEC. DIMENSION ARE IN MMM SURFACE FINISH: TOLLERANCES: LINEAR: ANGULAR:	FINISH:		DEBURR AND DO NOT SCALE DRAWING		REVISION
			BREAK SHARP EDGES		TITLE: SLOTTED ANGLE RACKS
NAME	SIGN. by	DATE	CLIENT: Alliance Air		
DRAWN			SCALE:1:1 SHEET		
CHK'D					
APPV'D					
MFG					
Q.A.		MATERIAL:			
REF. NO		SHEET A4			
		WEIGHT:			

2) ROOM - Unserviceable

TOTAL HEIGHT- 3212 mm

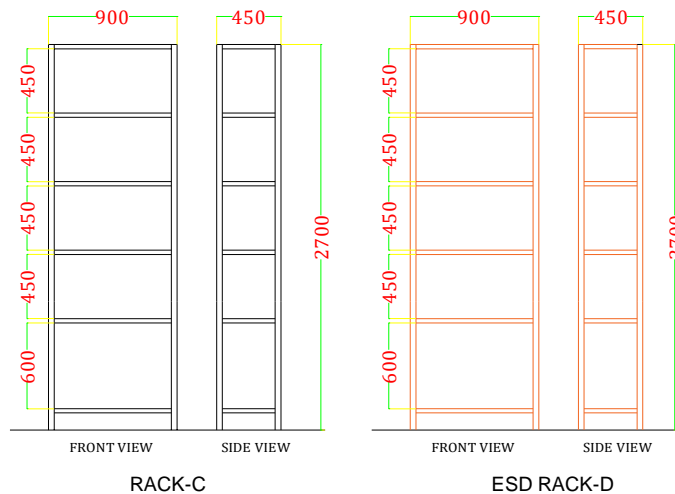
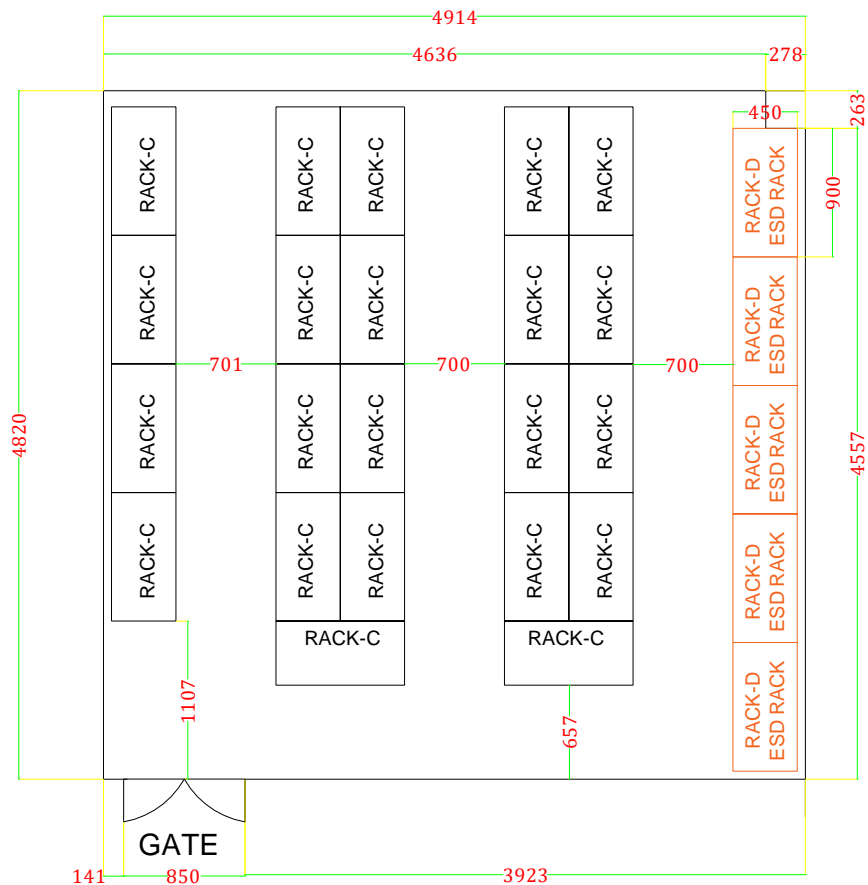

ROOM - 2

DIMENSION	SHELF	COMPARTMENT	H	L	D	Q
RACK-C	06	05	2700	900	450	22
RACK-D	06	05	2700	900	450	05

NOTE - ALL NEW RACK WITH NAME PLATE

UNLESS OTHERWISE SPEF. DIMENSION ARE IN MMM SURFACE FINISH: TOLLERANCES: LINEAR: ANGULAR:		FINISH:		DEBURR AND DO NOT SCALE DRAWING BREAK SHARP EDGES		REVISION	
				TITLE:: SLOTTED ANGLE RACKS			
				CLIENT:: Alliance Air			
				SCALE:1:1 SHEET			
DRAWN		SIGN. by		DATE			
CHK'D							
APPV'D							
MFG							
Q.A.				MATERIAL:			
REF. NO				SHEET A4			
				WEIGHT:			

3) ROOM - Rotable

TOTAL HEIGHT- 3252 mm

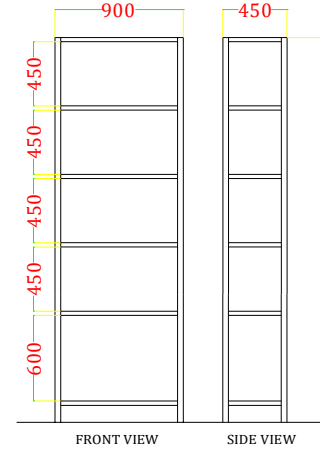
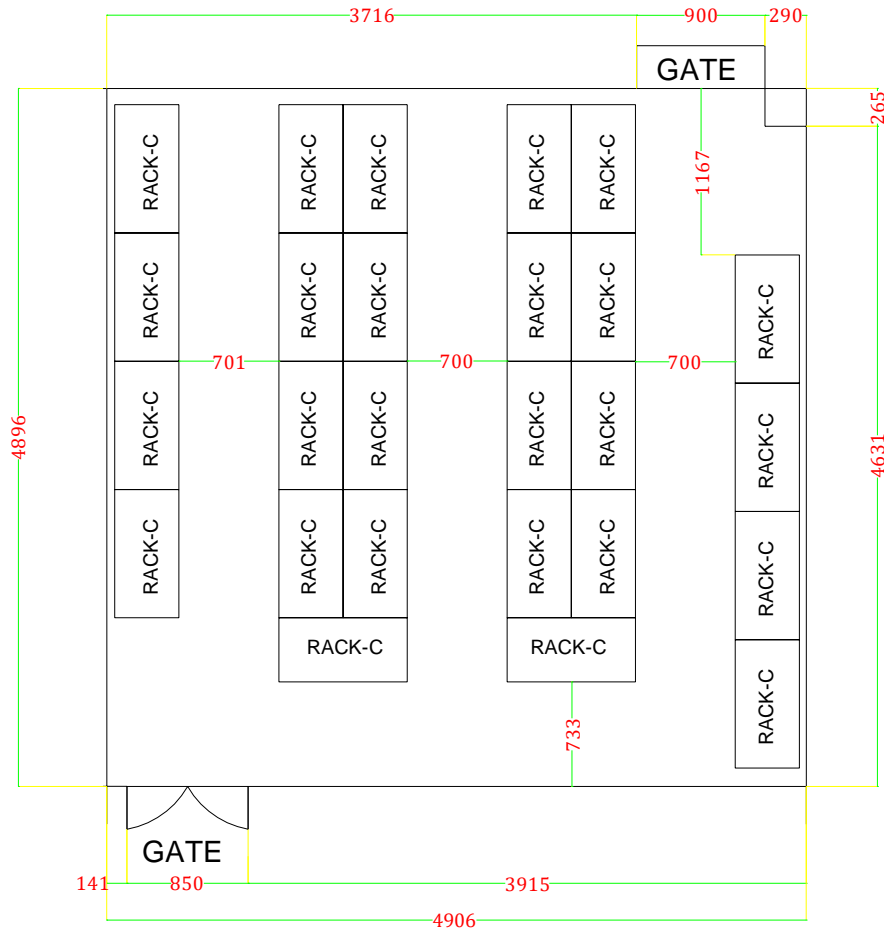

ROOM - 3 RACK-C

DIMENSION	SHELF	COMPARTMENT	H	L	D	Q
RACK-C	06	05	2700	900	450	26

NOTE - ALL NEW RACK WITH NAME PLATE

UNLESS OTHERWISE SPEF. DIMENSION ARE IN MMM SURFACE FINISH: TOLERANCES: LINEAR: ANGULAR:	FINISH:			DEBURR AND DO NOT SCALE DRAWING BREAK SHARP EDGES	REVISION
	TITLE:: SLOTTED ANGLE RACKS				
DRAWN	NAME	SIGN. by	DATE	CLIENT:: Alliance Air	
CHK'D				SCALE:1:1 SHEET	
APPV'D					
MFG				MATERIAL: SHEET A4	
Q.A.					
REF. NO				WEIGHT:	

4.) ROOM - Rotable

TOTAL HEIGHT- 3216 mm

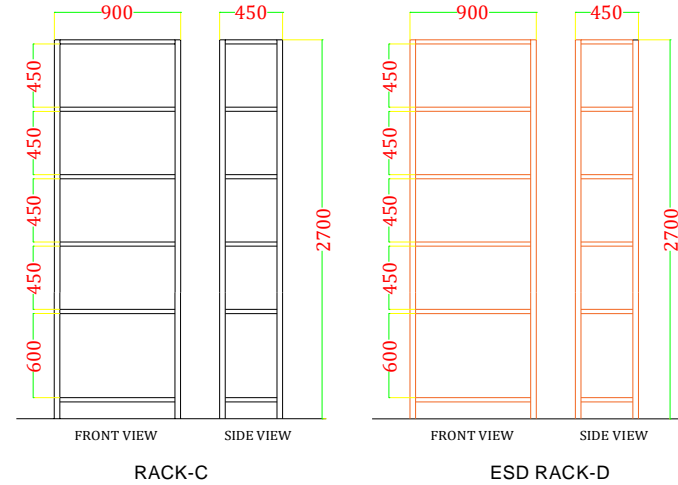
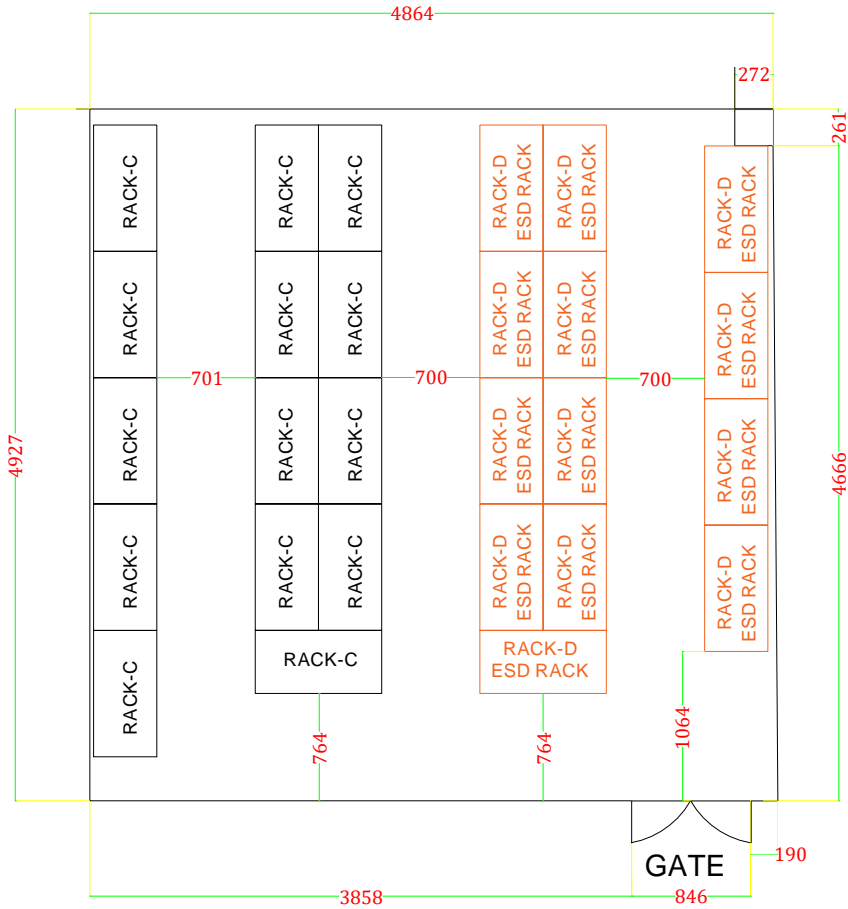

ROOM - 4

DIMENSION	SHELF	COMPARTMENT	H	L	D	Q
RACK-C	06	05	2700	900	450	14
RACK-D	06	05	2700	900	450	13

NOTE - ALL NEW RACK WITH NAME PLATE

UNLESS OTHERWISE SPEF. DIMENSION ARE IN MMM SURFACE FINISH: TOLLERANCES: LINEAR: ANGULAR:		FINISH:		DEBURR AND DO NOT SCALE DRAWING BREAK SHARP EDGES		REVISION	
				TITLE: SLOTTED ANGLE RACKS			
				CLIENT: Alliance Air			
				SCALE: 1:1 SHEET			
DRAWN	NAME	SIGN. by	DATE	MATERIAL:			
CHK'D				SHEET A4			
APPV'D				WEIGHT:			
MFG							
Q.A.							
REF. NO							

5.) OFFICE ROOM

TOTAL HEIGHT- 3042 mm

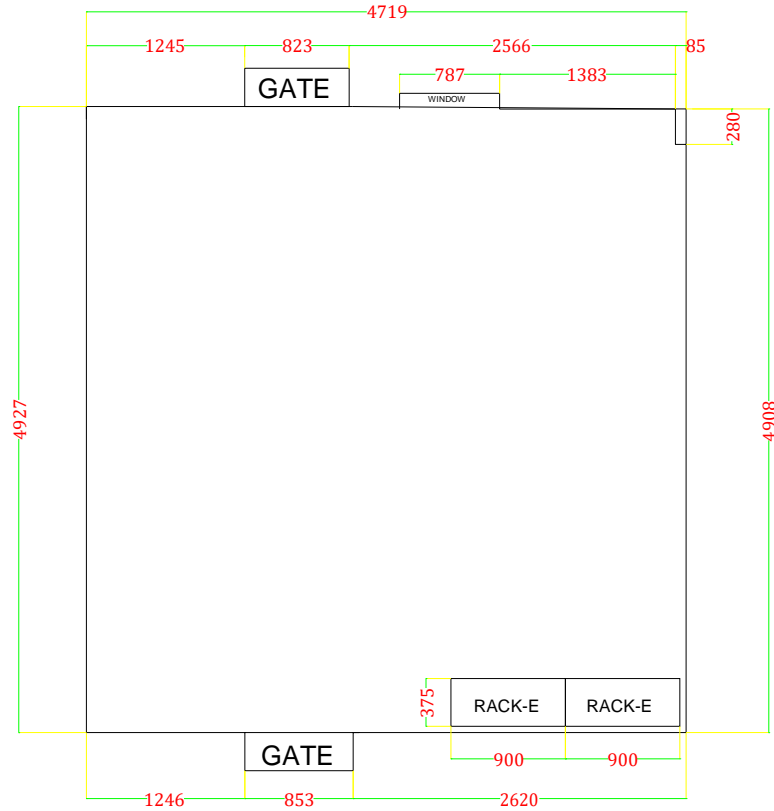

NOTE - In Tyre Racks, Big tyres will come on 1st level and 2nd level, small tyres will be placed on 3rd level

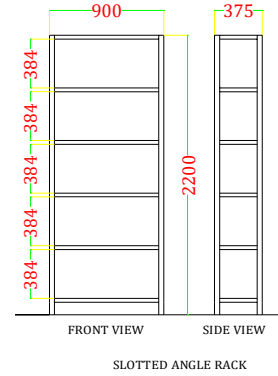

SLOTTED ANGLE RACKS(FILE RACKS)

DIMENSION	SHELF	COMPARTMENT	H	L	D	Q
RACK-E	06	05	2200	900	375	02

NOTE - ALL NEW RACK WITH NAME PLATE

UNLESS OTHERWISE SPEF. DIMENSION ARE IN MMM SURFACE FINISH: TOLLERANCES: LINEAR: ANGULAR:		FINISH:		DEBURR AND DO NOT SCALE DRAWING BREAK SHARP EDGES		REVISION	
				TITLE:: SLOTTED ANGLE RACKS			
				CLIENT:: Alliance Air			
				SCALE:1:1 SHEET			
DRAWN		SIGN. by		DATE			
CHK'D							
APPV'D							
MFG							
Q.A.				MATERIAL:			
REF. NO				SHEET A4			
				WEIGHT:			

6.) ROOM QUARANTINE

TOTAL HEIGHT - 3229 mm

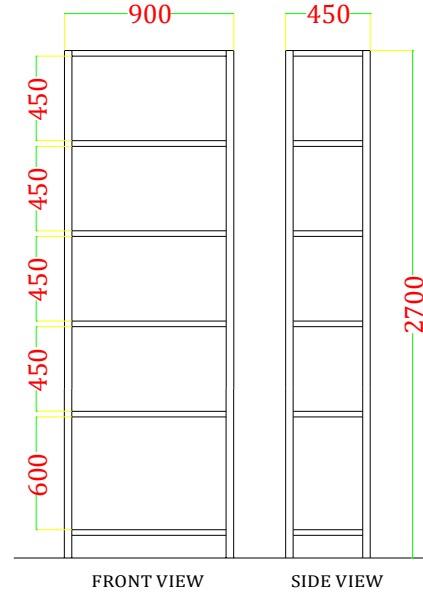
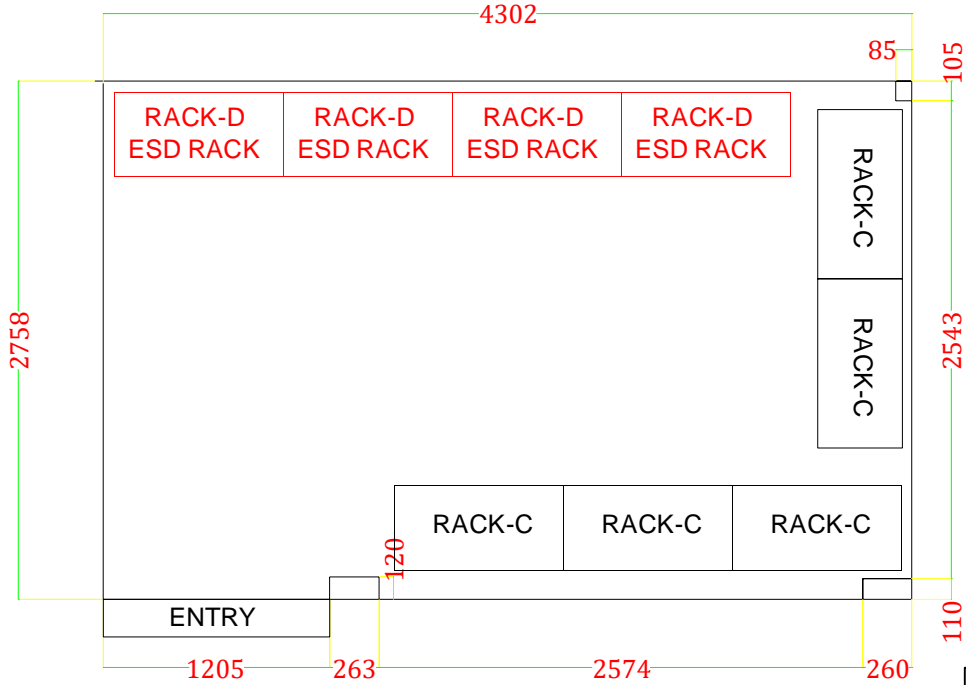

RACK-C

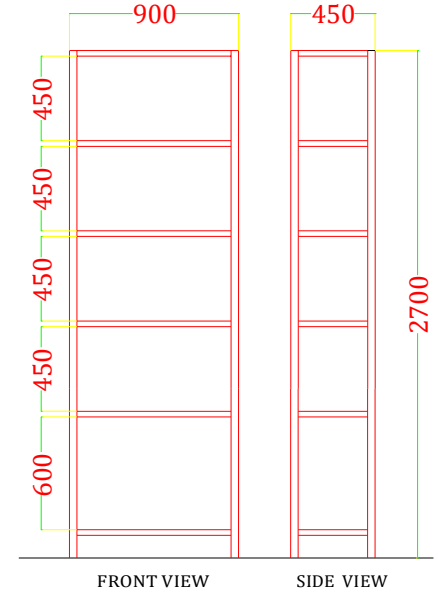

ESD RACK-D

NOTE - ALL NEW RACK WITH NAME PLATE

DIMENSION	SHELF	COMPARTMENT	H	L	D	Q
RACK-C	06	05	2700	900	450	05
ESD RACK-D	06	05	2700	900	450	04

UNLESS OTHERWISE SPEF. DIMENSION ARE IN MMM SURFACE FINISH: TOLLERANCES: LINEAR: ANGULAR:	FINISH:		DEBURR AND DO NOT SCALE DRAWING BREAK SHARP EDGES	REVISION
	TITLE:: SLOTTED ANGLE RACKS			
NAME	SIGN. by	DATE	CLIENT:: Alliance Air	SCALE:1:1 SHEET
DRAWN				
CHK'D			MATERIAL: SHEET A4	WEIGHT:
APPV'D				
MFG				
Q.A.				
REF. NO				

7.) TYRE ROOM

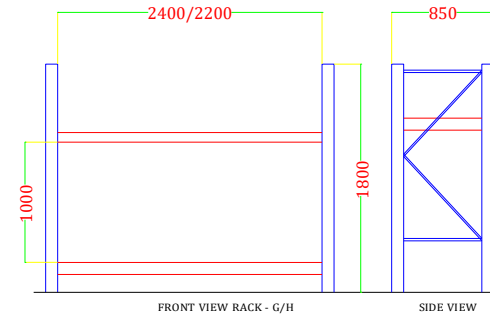
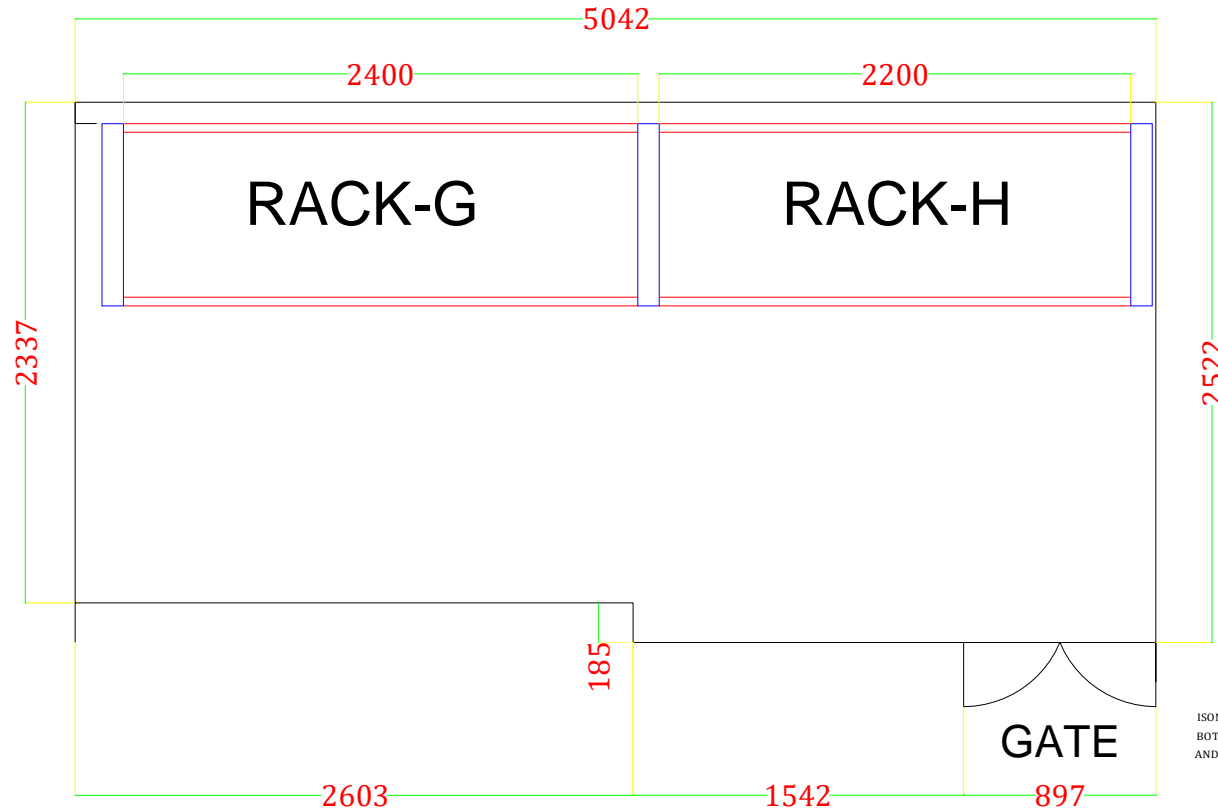

TYRE RACK

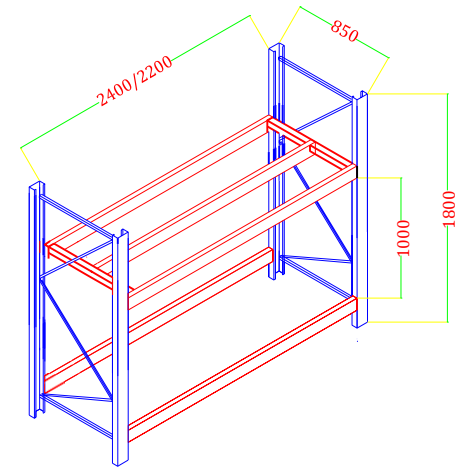

ISOMETRIC VIEW TYRE RACK
 BOTTOM LEVEL HAVE 02 BEAM
 AND UPPER LEVEL HAVE 03 BEAM PER LEVEL

TYRE RACK

DIMENSION	LEVEL	WEIGHT PER LEVEL	H	L	D	Q
RACK-G	02	300	1800	2400	850	01
RACK-H	02	300	1800	2200	850	01

BIG WHEEL SIZE - 900(DIA)*300(W) mm

NOSE WHEEL SIZE - 450(DIA)*175(W) mm

UNLESS OTHERWISE SPEF. DIMENSION ARE IN MMM		FINISH:		DEBURR AND BREAK SHARP EDGES		DO NOT SCALE DRAWING		REVISION	
SURFACE FINISH:						TITLE::			
TOLLERANCES:						TYRE RACKS			
LINEAR:						CLIENT::			
ANGULAR:						Alliance Air			
NAME	SIGN. by	DATE				SCALE:1:1		SHEET	
DRAWN									
CHK'D									
APPV'D									
MFG									
Q.A.						MATERIAL:			
REF. NO						SHEET A4			
						WEIGHT:			

8.) TOOL ROOM

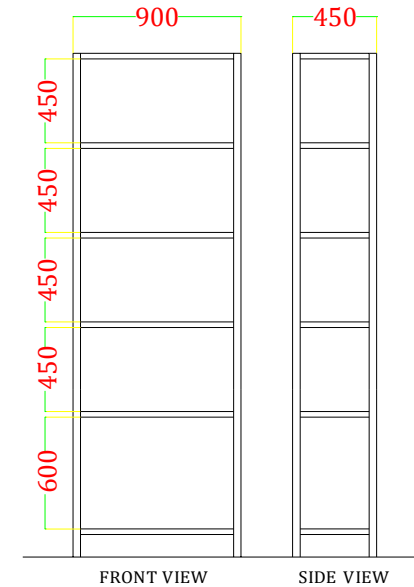
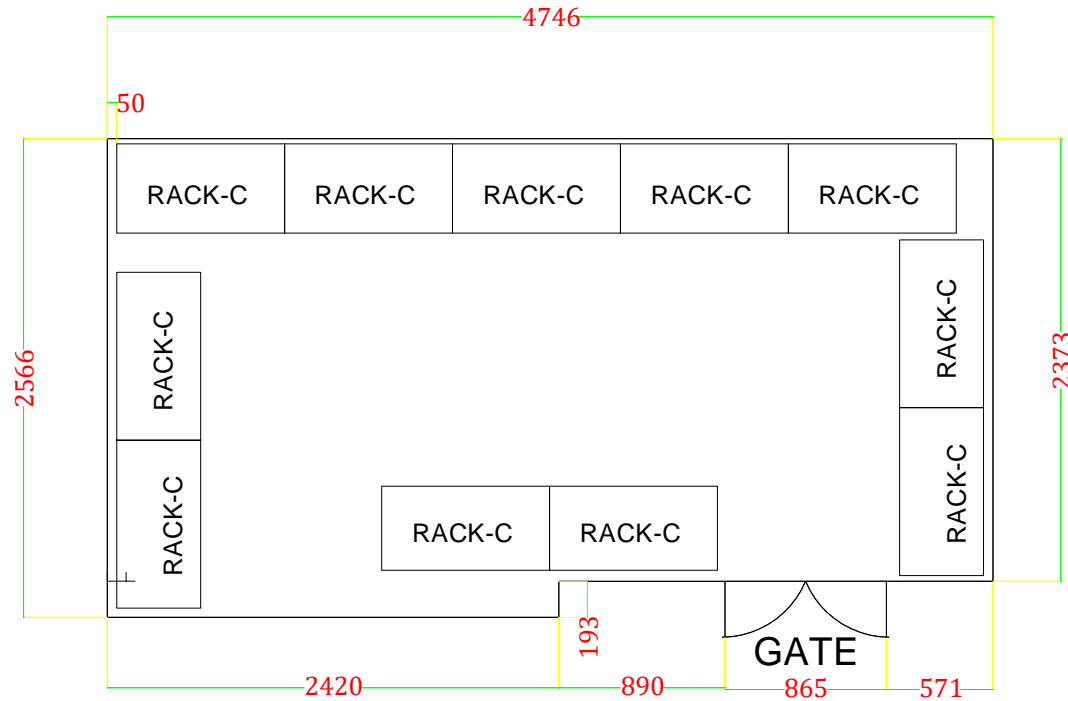

RACK-C

DIMENSION	SHELF	COMPARTMENT	H	L	D	Q
RACK-C	06	05	2700	900	450	11

NOTE - ALL NEW RACK WITH NAME PLATE

UNLESS OTHERWISE SPEC. DIMENSION ARE IN MMM SURFACE FINISH: TOLERANCES: LINEAR: ANGULAR:	FINISH:		DEBURR AND BREAK SHARP EDGES	DO NOT SCALE DRAWING	REVISION
	SIGN. by			TITLE:: SLOTTED ANGLE RACKS	
DRAWN	NAME	DATE		CLIENT:: Alliance Air	
CHK'D				SCALE:1:1 SHEET	
APPV'D					
MFG					
Q.A.			MATERIAL:		
REF. NO			SHEET A4		
			WEIGHT:		

9.) HARDWARE STORE FIRST FLOOR

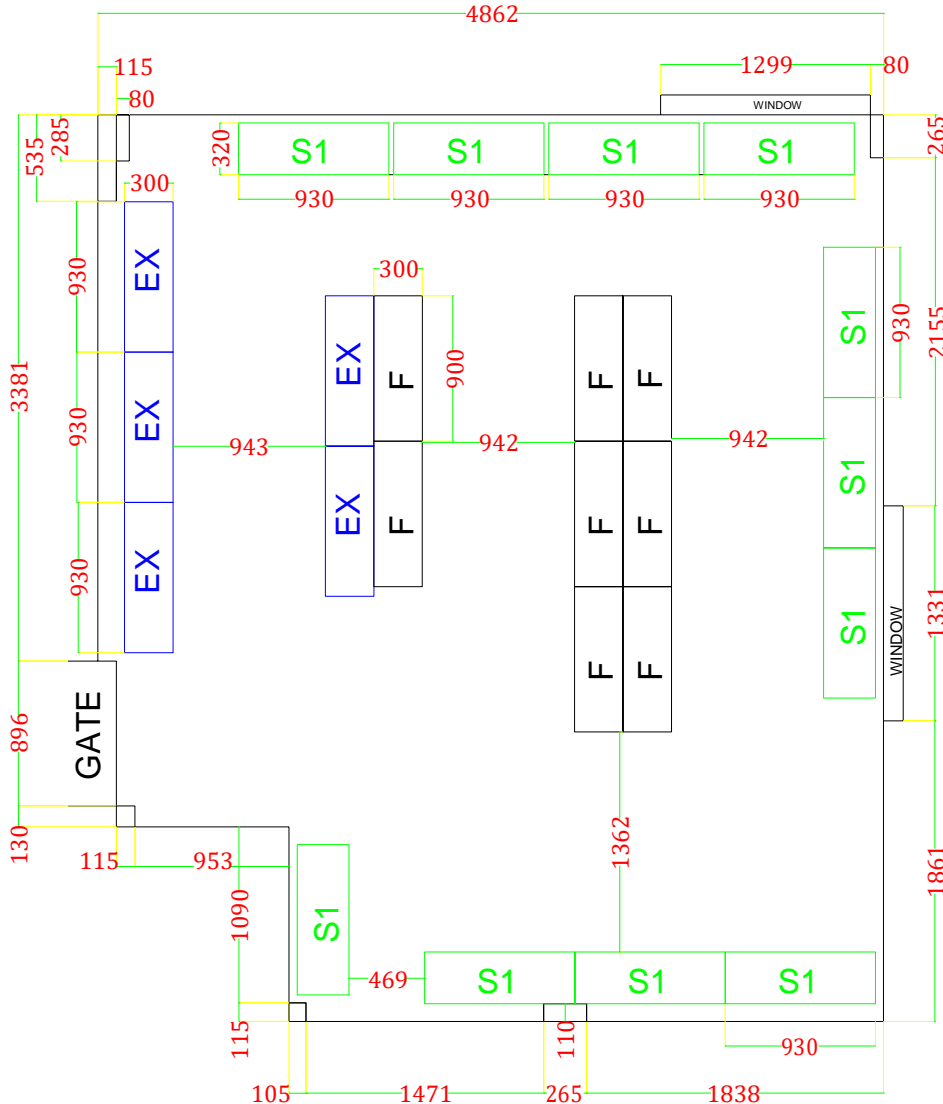

EX - EXISTING RACKS
S1 - SHIFTED RACKS

TOTAL HEIGHT - 3296 mm

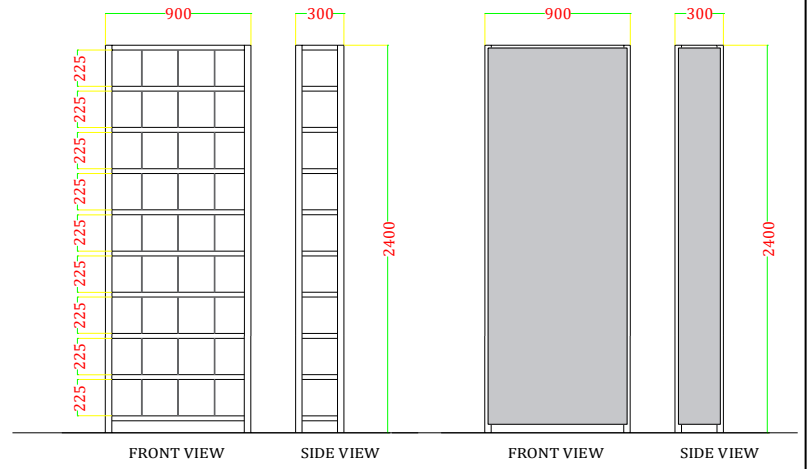

RACK-F

RACK-F with Back and Side Cladding

SLOTTED ANGLE RACKS WITH PARTITION AND CLADDING SHEET

DIMENSION	SHELF	COMPARTMENT	H	L	D	Q
RACK-F	10	36	2400	900	300	08

UNLESS OTHERWISE SPEF. DIMENSION ARE IN MMM SURFACE FINISH: TOLERANCES: LINEAR: ANGULAR:		FINISH:		DEBURR AND DO NOT SCALE DRAWING BREAK SHARP EDGES		REVISION	
						TITLE:: SLOTTED ANGLE RACKS	
						CLIENT:: Alliance Air	
DRAWN	NAME	SIGN. by	DATE				
CHK'D							
APPV'D							
MFG							
Q.A.				MATERIAL:			
REF. NO				SHEET A4			
				WEIGHT:			

10.) RUBBER STORE FIRST FLOOR

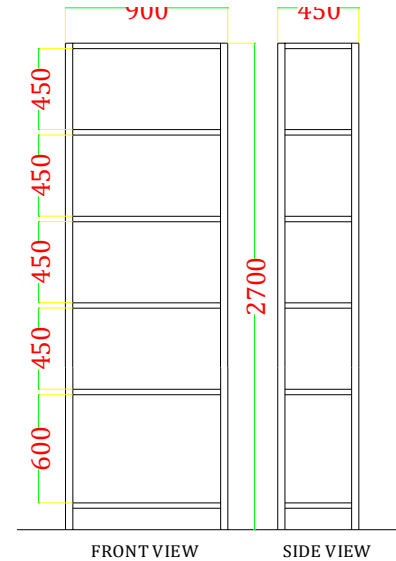
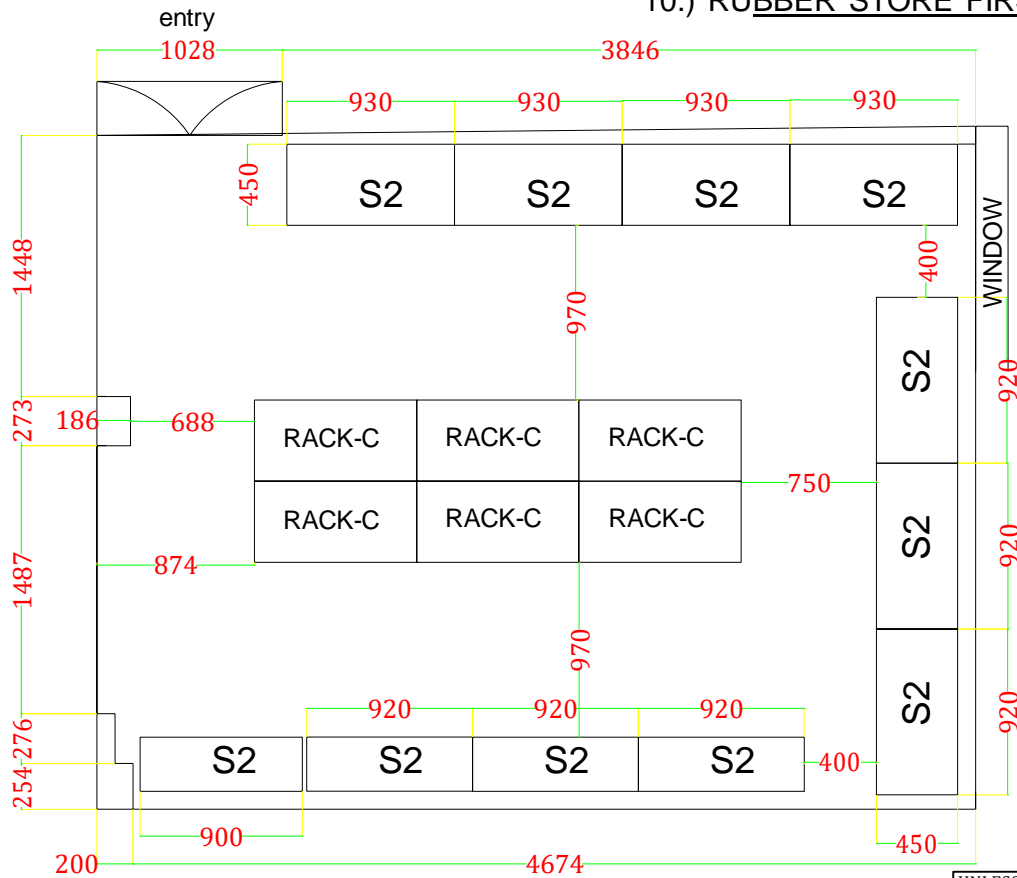

RACK-C

NOTE - ALL NEW RACK WITH NAME PLATE

S2 are existing Racks shifted

DIMENSION	SHELF	COMPARTMENT	H	L	D	Q
RACK-C	06	05	2700	900	450	06

UNLESS OTHERWISE SPEF. DIMENSION ARE IN MMM SURFACE FINISH: TOLERANCES: LINEAR: ANGULAR:	FINISH:		DEBURR AND DO NOT SCALE DRAWING BREAK SHARP EDGES	REVISION
	TITLE:: SLOTTED ANGLE RACKS			
DRAWN	NAME	SIGN. by	DATE	CLIENT:: Alliance Air
CHK'D				SCALE:1:1 SHEET
APPV'D				
MFG				MATERIAL: SHEET A4
Q.A.				
REF. NO				WEIGHT:

S.no.	Description	Qty.	Rate(Rs.)	Amount(Rs.)
<u>ROOM-1 R & D</u>				
<u>ESD Rack-A (with Name Plate)</u>				
1.	Slotted Angle Rack Size: 1800x1000x600 mm, having 04 Shelves of size 1000x600x18G making 03 compartments, the Rack is fitted with Slotted Angle 40 x40 x14G along with galvanized nut bolts, & Powder Coated in Orange color.	01 Nos.		
<u>Rack-B(with Name Plate)</u>				
2.	Slotted Angle Rack Size: 1800x1000x600 mm, having 04 Shelves of size 1000x600x18G making 03 compartments, the Rack is fitted with Slotted Angle 40 x40 x14G along with galvanized nut bolts, & Powder Coated in grey color.	02 Nos.		
<u>ROOM – 2 Unserviceable</u>				
<u>Rack-C(with Name Plate)</u>				
3.	Slotted Angle Rack Size: 2700x900x450 mm, having 01 Bottom Shelves of size 900x450x18G and 05 Shelves of size 900x450x20G making 05 compartments, the Rack is fitted with Slotted Angle 40 x40 x14G along with galvanized nut bolts, & Powder	22 Nos.		

Coated in grey color.

ESD Rack-D(with Name Plate)

4. Slotted Angle Rack Size: 2700x900x450 mm, 05 Nos.
having 01 Bottom Shelves of size
900x450x18G and 05 Shelves of size
900x450x20G making 05 compartments, the
Rack is fitted with Slotted Angle 40 x40 x14G
along with galvanized nut bolts, & Powder
Coated in Orange color.

ROOM – 3 Rotable

Rack-C(with Name Plate)

5. Slotted Angle Rack Size: 2700x900x450 mm, 26 Nos.
having 01 Bottom Shelves of size
900x450x18G and 05 Shelves of size
900x450x20G making 05 compartments, the
Rack is fitted with Slotted Angle 40 x40 x14G
along with galvanized nut bolts, & Powder
Coated in grey color.

ROOM – 4 Rotable

Rack-C(with Name Plate)

6. Slotted Angle Rack Size: 2700x900x450 mm, 14 Nos.
having 01 Bottom Shelves of size
900x450x18G and 05 Shelves of size
900x450x20G making 05 compartments, the
Rack is fitted with Slotted Angle 40 x40 x14G
along with galvanized nut bolts, & Powder
Coated in grey color.

ESD Rack-D(with Name Plate)

7. Slotted Angle Rack Size: 2700x900x450 mm, 13 Nos.
having 01 Bottom Shelves of size
900x450x18G and 05 Shelves of size
900x450x20G making 05 compartments, the
Rack is fitted with Slotted Angle 40 x40 x14G
along with galvanized nut bolts, & Powder
Coated in Orange color.

ROOM – 5 Office

Rack-E(with Name Plate)

8. Slotted Angle Rack Size: 2200x900x375 mm, 02 Nos.
having 06 Shelves of size 900x375x20G
making 05 compartments, the Rack is fitted
with Slotted Angle 40 x40 x14G along with
galvanized nut bolts, & Powder Coated in grey
color.

ROOM – 6 Quarantine

Rack-C(with Name Plate)

9. Slotted Angle Rack Size: 2700x900x450 mm, 05 Nos.
having 01 Bottom Shelves of size

900x450x18G and 05 Shelves of size 900x450x20G making 05 compartments, the Rack is fitted with Slotted Angle 40 x40 x14G along with galvanized nut bolts, & Powder Coated in grey color.

ESD Rack-D(with Name Plate)

10. Slotted Angle Rack Size: 2700x900x450 mm, having 01 Bottom Shelves of size 900x450x18G and 05 Shelves of size 900x450x20G making 05 compartments, the Rack is fitted with Slotted Angle 40 x40 x14G along with galvanized nut bolts, & Powder Coated in Orange color. 04 Nos.

ROOM – 7 Tyre Room

Heavy Duty Tyre Rack - G

11. Heavy Duty Tyre Racks Size: 1900(H) x2400(L) x850(D) mm having 02 Loading Level in which Upper Level having 03 Horizontal Beam and Bottom Level having 02 Horizontal Beam, with pair of Upright Frame (2 x2 pillars) in blue & Horizontal load beams in orange color, without Deck Panel(weighting capacity 300 kg UDL per Level) Starter Bay 01 Nos.

Heavy Duty Tyre Rack - H

12. Heavy Duty Tyre Racks Size: 1900(H) x2200(L) x850(D) mm having 02 Loading Level in which Upper Level having 03 Horizontal Beam and Bottom Level having 02 Horizontal Beam, with pair of Upright Frame (2 x2 pillars) in blue & Horizontal load beams in orange color, without Deck Panel(weighting capacity 300 kg UDL per Level) Extended Bay 01 Nos.

ROOM – 8 Tool Room

Rack-C(with Name Plate)

13. Slotted Angle Rack Size: 2700x900x450 mm, having 01 Bottom Shelves of size 900x450x18G and 05 Shelves of size 900x450x20G making 05 compartments, the Rack is fitted with Slotted Angle 40 x40 x14G along with galvanized nut bolts, & Powder Coated in grey color. 11 Nos.

ROOM – 9 Hardware Store First Floor

Rack-F

14. Slotted Angle Rack Enclosed Size: 2400(H) x900(L) x 300(D) mm, having 10 Shelves of size 900 x300x20G, with 27 partition plates 08 Nos.

making 36 compartments, the rack is fitted with Slotted Angle 40x40x14G and the rack is closed in three side (Left, Right and Back) by the help of cladding sheet, along with galvanized nut bolts, and corner plates to give maximum rigidity & Powder coated with grey color.

ROOM – 10 Rubber Store First Floor
Rack-C(with Name Plate)

15. Slotted Angle Rack Size: 2700x900x450 mm, 06 Nos.
having 01 Bottom Shelves of size
900x450x18G and 05 Shelves of size
900x450x20G making 05 compartments, the
Rack is fitted with Slotted Angle 40 x40 x14G
along with galvanized nut bolts, & Powder
Coated in grey color.

